



Approved By :
Suruhanjaya Tenaga
 Energy Commission

Tecnocontrol

GAS DETECTOR

SERIES SE138

Stand Alone industrial gas detector, with replaceable cartridge sensor ATEX certified for Zone 1.

- Ex marking **Ex**: II 2G Ex d IIC T6 Gb
- No. 3 Alarm relays solid state type. MAX resistive load 24V/1A SPST
- No. 1 Fault relay solid state type. MAX resistive load 24V/1A SPST
- Alarm levels (relays) programmables via DIP-Switch
- No. 1 linear 4÷20 mA current output
- Terminals plug-in polarized type

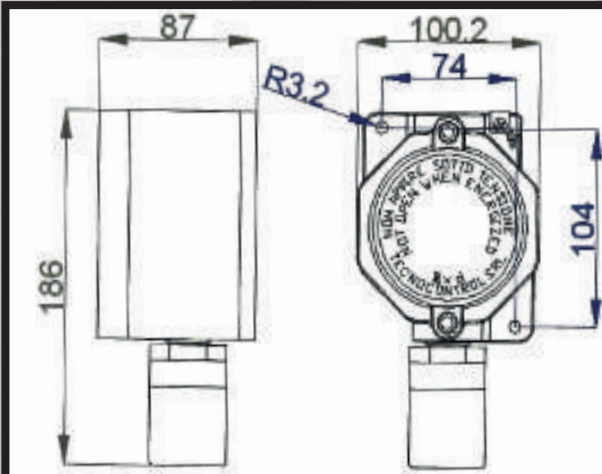

Code	Gas detected	Cartridge replacement	Type sensor	Measuring range	Power Supply	Electrical input	Output	Calibration cylinder	Average time in clean air (years)	Maximum storage time (years)
SE138KM	Methane	ZSK02/EX	Catalytic	0÷20% LEL	12÷24Vdc (-10/+15%)	2	No.4 Solid state type Relays 24V/1A SPST No.1 Linear 4÷20mA current Output	B0006	5	5
SE138KG	LPG									
SE138KI	Hydrogen									
SE138KB	Petrol	ZSK04/EX	Electrochemical	0÷300 ppm				B0014	2	1 month
SE138EA	Ammonia	ZSEA1/EX		0÷100 ppm						
SE138EH	Hydrogen sulphide	ZSEH1/EX		0÷100 ppm						

COMeT
 COMeT
 INTEGRATED
 SDN BHD
 502054-M

No. 23, Jalan Gitar 33/3, Elite Industrial Park, Seksyen 33, 40350, Shah Alam, Selangor, Malaysia.
 Email: sales@comet-integrated.com Website: www.comet-integrated.com