

GTQ-X Point type fixed gas detector is designed for industrial and commercial use. It is a system-type detector. The detector has the characteristics of a small and compact structure, explosion-proof, stable and reliable, easy operation and maintenance, and flexible wiring.

GTQ-X Fixed Gas Detector

SPECIFICATIONS:

Model	GTQ-X
Sensor	Catalytic
Working Voltage	DC24V±6V
Ingress Protection	IP67
Alarm Deviation	±3%LEL
Signal	4 - 2mA, 3 wires
Relay	Low alarm relay, dry contact 1 A@DC24V
Status	Fault : Yellow, Alarm : Red, Monitoring : Green
Ex rating	Ex db IIC T6 Gb/ Ex tb III C T80°C Db
Size	115mm x 150mm x 60mm
Weight	<800g
Housing	Aluminium alloy
Sensor life	3 years (catalytic)



TERMINALS:



STRUCTURE DIAGRAM:

GTQ-X gas detector is mainly composed of a metal shell, a sensor module, a circuit board, ect. The shell is mainly composed of an upper cover, an O-ring, a lower shell, a scaling plug, a protective cover, a bulkhead, and a plug. The shell plays a role of explosion-proof and protection. The sensor module and the transmitter group are connected by a 5-core cable. The detector structure diagram is shown below:

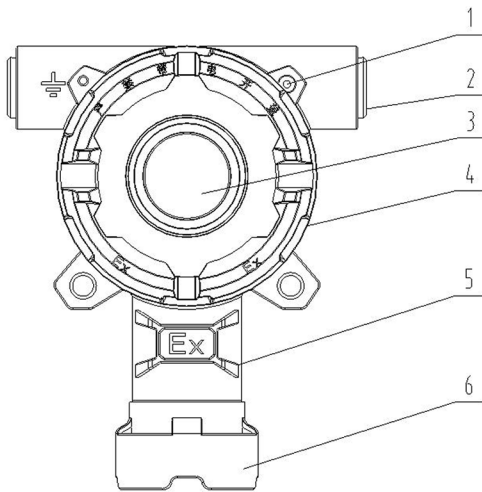

Serial number	Part Name	Serial number	Part Name
1	Locking screw	4	Cover
2	Plug	5	Gas chamber (sensor)
3	Upper cover (display window)	6	Waterproof cover

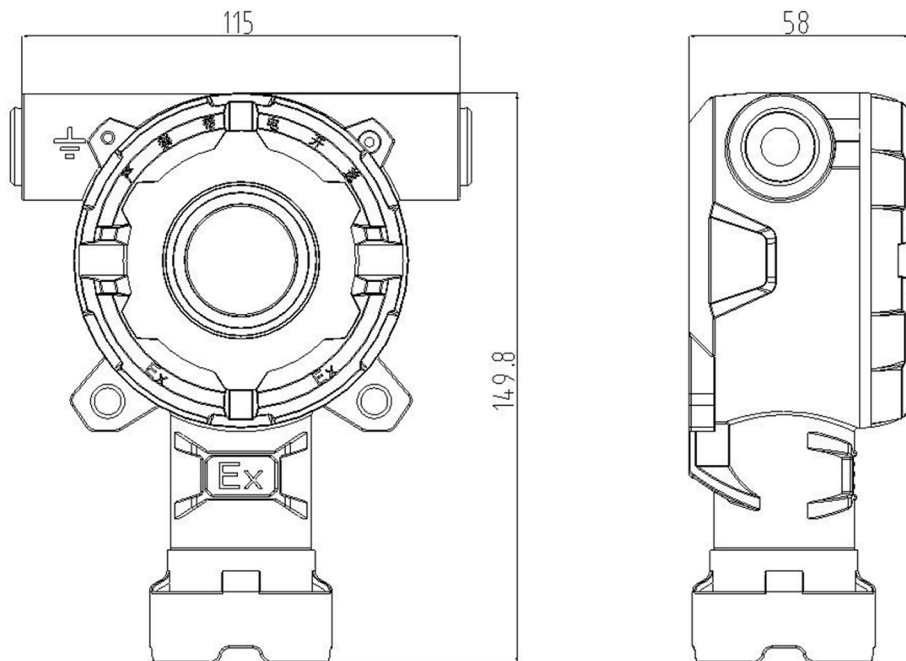

Dimensions: Unit (mm)